



Contents

- 3. Who are we?
- 5. Omega
- 7. Sigma
- 9. Delta Glazed Movable Wall
- 10. Zeta Straight Slider
- 11. Alpha Concertina
- 13. Rho-Retreat Pods
- 14. Acoustic Wall Baffles
- 15. Clients & Case Studies
- 17. Manufacturing
- 19. Service & Maintenance



Who are we?



Manufactured in the UK

We offer high quality products tailored via exceptional workmanship

Make the most of your existing space

Flexibility of space is becoming increasingly important, the addition of sliding folding partitions is an ideal way of utilising existing space efficiently, effectively and economically.

Whether you want to sub-divide a classroom or office, sliding partitions can allow for more than one function in a room or create a number of areas in a large floor space, whatever the needs we have a solution to suit all requirements and budgets.

Open and close walls & partitions with ease

Operation and handling is a key element within each movable wall panel. The sheer ease that our panels glide across aluminium head tracks shows the quality we offer.

The demand on the user operation varies depending on each individual system, with this in mind the principle in design and ease of manoeuvre is a key element of research carried through all options.

Benefit from long lasting build quality

We utilise the expertise of in house design and knowledge to manufacture a system regarded as a market leader.

The very best in technology and workmanship is used to develop, create and build lightweight panels that can be delivered and installed with ease.

All parts have been through a rigorous testing process to ensure longevity of all panels.

Research & development exhibits high standards and each panel is complemented with flush edges and a sub structure perfect for handling and operation.

THE VAULT



Omega

Ideally suited for high specification applications due to the sheer flexibility, numerous stacking arrangements and the system's

Stacking Options

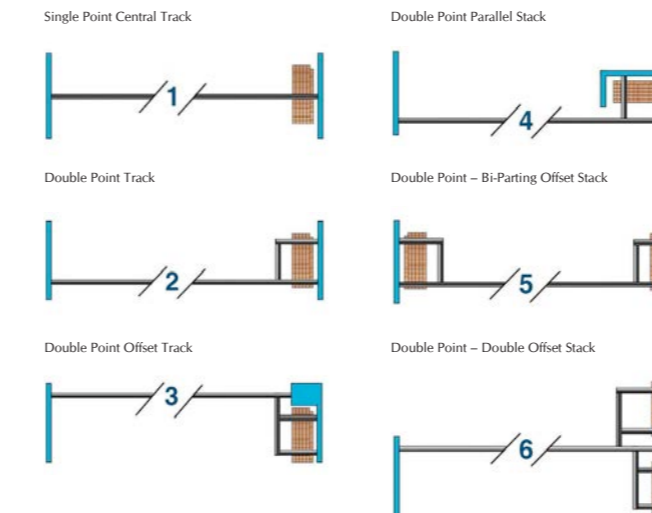

Suspension Options

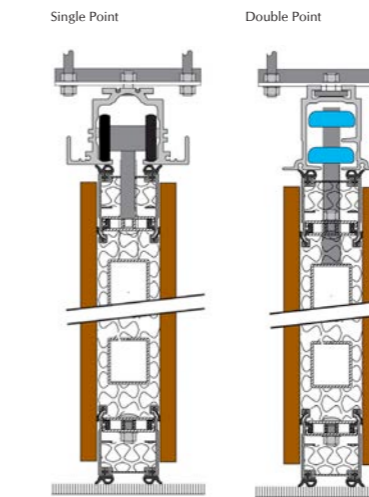

Introduction

The Omega Range is our individual panel partition system offering an acoustic insulation rating of up to 59dB. Ideally suited for high specification applications due to the sheer flexibility, numerous stacking arrangements available and the impressive acoustic qualities this system offers.

The panels are operated by means of an internal scissor-jack mechanism and move effortlessly along an aluminium head track, when closed they form a secure fixed wall.

Technical Specs

- Acoustic rating from 39-59dB laboratory tested to ISO 140 Part 3
- Applications up to 10,000mm high
- Top hung with no floor track
- Hydraulic Strut operating mechanism
- Available with virtually any surface finish
- Ideal for conference centres, hotels, offices & schools
- Angled, glazed, corner or junction panels for maximum flexibility
- Single or double point suspension for versatile stacking options
- Panels with hinged pass door, single or double leaf inset pass door panels for access through
- Panel widths from 650mm-1250mm
- Nominal panel thickness 100mm
- Full maintenance contracts available
- Manufactured in the UK



Sigma

Stacking Options

Single Wing – End Folding



Single Wing – Centre Folding

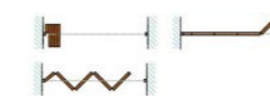

Bi Wing – End Folding



Bi Wing – Centre Folding

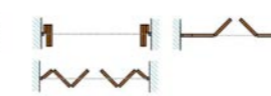

Suspension Options

Top Hung

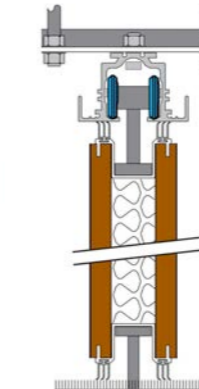

Bottom Rolling

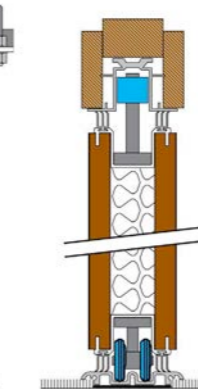

For added flexibility, or when there is no suitable structure to suspend from, the Sigma can be supplied with a low profile floor track.

Introduction

The Sigma Range is a continuously hinged system offering a mid level acoustic performance.

With multiple fixed rubber sweep seals it can offer an acoustic insulation up to 45dB.

For added flexibility, or when there is no suitable structure to suspend from, the Sigma can be supplied as a bottom rolling option, running along a low profile floor track.

Technical Specs

- Acoustic rating from 38-45dB laboratory tested to ISO 140 Part 3
- Applications up to 3600mm high
- Top Hung or Bottom Rolling with floor track
- Available with virtually any surface finish
- Corner and glazed panels for added flexibility
- Centre or Endfold configuration
- Communicating door panel within as standard
- Panel widths from 600mm – 850mm
- Panel thickness 70mm or 100mm
- Full maintenance contracts available
- Manufactured in the UK



Delta Glazed Movable Wall

Ideally suited for high specification applications due to the sheer flexibility and numerous stacking arrangements.

Stacking Options

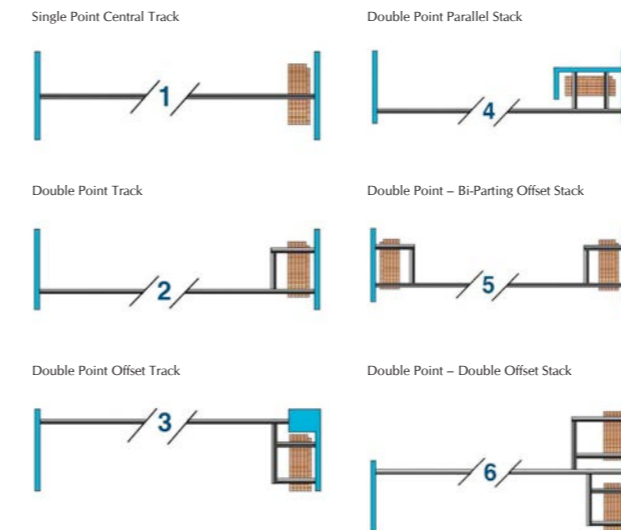

Suspension Options

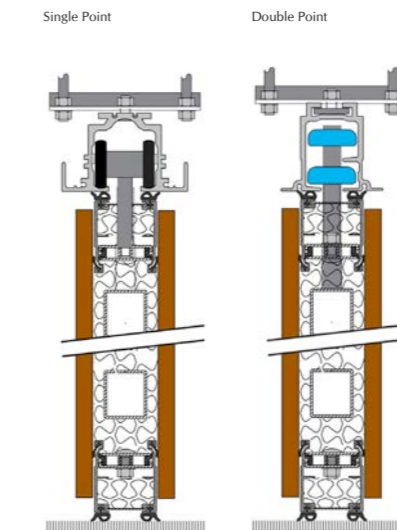

Introduction

The Delta115 Range is a fully glazed partition offering acoustic ratings up to 54dB.

Panel seals are operated semi automatically and move effortlessly along an aluminium head track, when closed they form a secure fixed wall.

Technical Specs

- Acoustic rating from 44-54dB
- Applications up to 3600mm high
- Single / Twin Point Suspension
- 840mm – 1300mm Panel Widths
- Ideal for conference centres, hotels, offices & schools
- Panels with hinged pass door, single or double leaf inset pass door panels for access through
- Nominal panel thickness 115mm
- Full maintenance contracts available



Zeta Straight Slider

A push and pull system, which can be supplied bi parting or single wing, available top hung configuration or with a low profile floor track.

Stacking Options

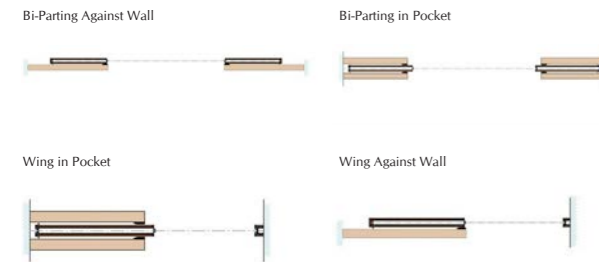

Suspension Options

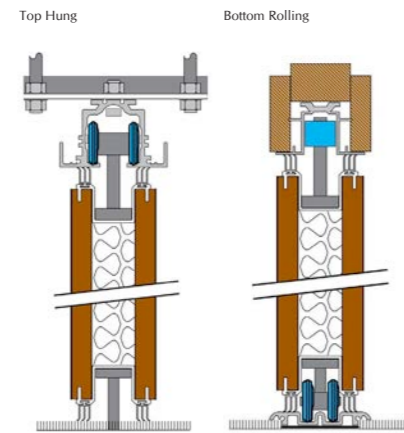

Introduction

The Zeta Straight Slider is an easy to use top hung, push/pull straight sliding system offering a mid level acoustic performance. Fitted with fixed top and bottom brush seals it can offer an acoustic insulation up to 38dB.

With a maximum panel width of 1,220mm, panels can be joined together on site to form larger openings. For added flexibility, or when there is no suitable structure to suspend from, the Sigma Straight Slider can be supplied as a bottom rolling option, running along a low profile floor track.

Technical Specs

- Acoustic rating 38dB
- Applications up to 3,050mm high
- Maximum single panel width 1,220mm
- Panels can be joined together on site to form larger openings
- Maximum single opening width 3,660mm (3 panels joined together)
- Maximum bi-parting opening width 7,320mm (2 x 3 panels joined together)
- Top hung with no floor track or floor supported options
- Available with virtually any surface finish
- Ideal for apartment blocks, flats, offices, hotels, leisure centres
- Panel widths from 400mm-1,220mm
- Full maintenance contracts available
- Manufactured in the UK

Alpha Concertina

This range of Vinyl Concertina partitions offering a low cost alternative to the higher specification movable walls.

Stacking Options

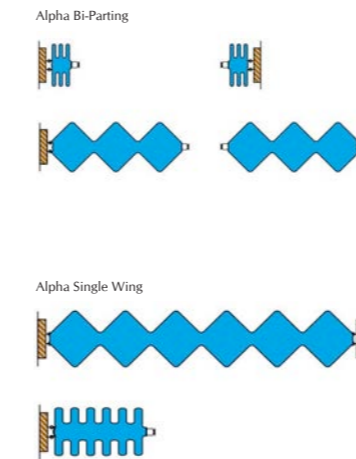

Suspension Options

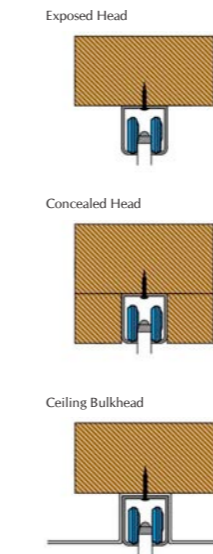

Introduction

Where budget is the primary factor, the Alpha Range of Vinyl Concertina partitions offers a low cost alternative to the higher specification movable walls.

An easy to use system, the Alpha Range is ideally suited for applications such as schools, nurseries, village halls and hospitals.

Constructed with a steel pantograph frame and covered with a strong and durable fabric backed vinyl produced by the leading wall covering supplier Kayospruce.

Technical Specs

- Acoustic rating from 15-35dB
- Applications up to 6,000mm high
- Unlimited opening width
- Available as single wing, bi-parting or floating units
- Wider internal hinges available to reduce stacking depth
- Top hung with no floor track and floor supported options
- Surface finish is class '1' & '0' to BS476
- Fully washable and mould & mildew resistant
- Partitions can be curved to a maximum 1,000mm radius
- Partitions can incorporate vision panels
- Full maintenance contracts available
- Manufactured in the UK



Rho-Retreat Pods

Our Rho-Retreat is a customisable addition to any workplace, instantly creating private meeting or workspace where none existed previously. They are a Functional, flexible meeting space allowing for small numbers of people to get together in a creative space.

Introduction

We offer a large amount of customisable features including sustainable products, interior lighting, charging options, Bluetooth speakers and much more.

There are also a vast range of finishes which allow a fully branded, creative space, from fabric finishes, to graphic wraps.

Technical Specs

- Upholstery can run around the whole booth or outer sides
- They can be fitted with or without a back panel
- MFC/ Graphics and upholstery options
- End chair supports can be MFC finish or upholstered to match
- Power options mounted either within the back panel or mounted to the table. Both USB A+C and uk 3 pin plug available
- Either high efficiency spot lights (non- upholstered) or traditional lamp (upholstered roof only)
- 100mm frame surround to carry cables and support the structure
- Powder coated table frame



Acoustic Wall Baffles

Acoustic specialists providing sound control solutions for building interiors. Working exclusively for many years providing acoustic solutions, products and advice.

Introduction

Standard and bespoke products manufactured in the UK with advance CNC machinery producing complex designs and shapes.

Noise is defined as unwanted sound. Some sounds are preferable such as music but other sounds cause stress such as loud speech.

Soundsorba can help to comply with BB93 guidelines for schools.

Product Range

- Wallsorba
- Wallsorba Shapes
- Cloudsorba
- Woodsorba
- Bafflesorba

Clients

We have been honoured to work with a broad range of clients, some of which can be seen below

Our mission is to deliver our excellent product with a first class service



Recent Projects



BBC DIY SOS Big Build
Grenfell Tower Community Centre



Ikea



Interserve Head Office

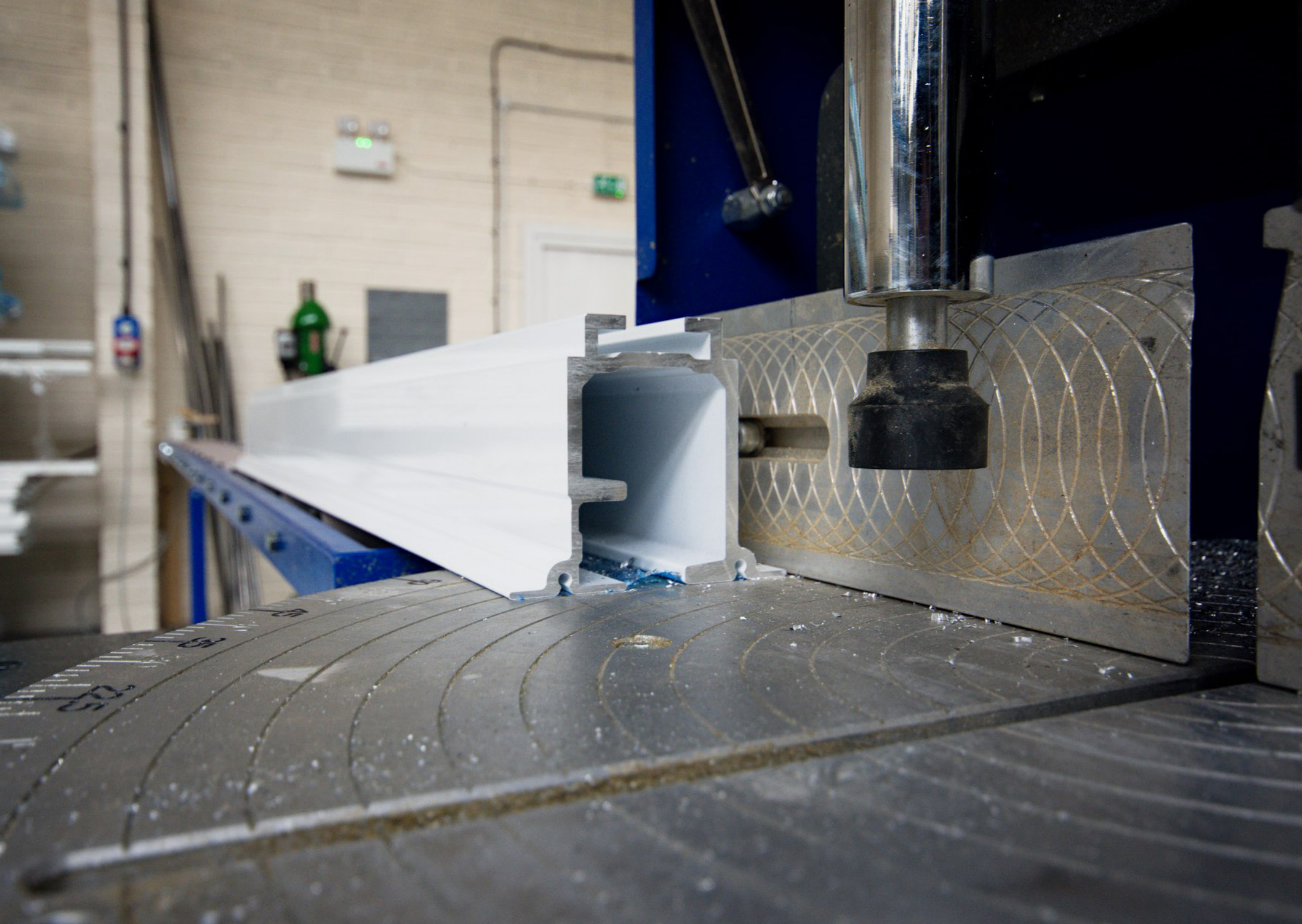

Manufacturing

**MADE IN
BRITAIN** 

Manufacturing plant based in Worcester

We pride ourselves on workmanship, quality control and most importantly customer service. With the right team and our new innovative product we strive to be at the forefront of the Movable Wall Industry.

Manufactured in house for superior quality

Research & Development is a key element to make sure we keep ahead of competitors and to stay at the forefront of the industry.

With many years of planning, design and technical knowledge our team can now offer a manufacturing plant with state of the art product development, testing facilities and a showroom for client meetings.

It is vital to understand the elements of each component and how panels are formed to showcase a secure fixed wall once on site.









We offer and welcome client show rounds and will advise from the outset on any design and layout proposals.

As a UK manufacturer we offer quicker lead times, replacement parts and full on site acoustic testing on request.





Service & Maintenance

-  **Cleaning and Lubrication** to track and roller system
-  **Roller Inspections** and replacements
-  **Operable Seal Checks** to ensure optimum seal
-  **Full Service Reports** of all servicing completed
-  **Profile Inspections** to ensure efficient sliding
-  **Replacement Parts** and operating handles
-  **Operable Wall Relocation** relocation of existing walls
-  **Full Guarantee** on all works undertaken

Our service contract offers a three-tiered support:

- High (walls used on a daily basis) - 3 service visits per year
- Medium (walls used on a weekly basis) - 2 service visits per year
- Low (walls used occasionally) - 1 service year per year

Benefits of our service contract includes:

- 20% discount of the service visit
- Priority response for all service contract clients
- Calendar scheduled visits to ensure a continuous smooth operation

Keep those cogs turning

We are specialists in installation, repair and servicing all aspects of Movable Walls. Given the right care and maintenance a movable wall will last for many years and operate at its peak performance. As well as repairs, Ce Solutions can provide preventative maintenance and servicing contracts on a regular basis to suit you.

For more information on our service and maintenance contract offers call us now on 01905 422 533

Preventative Maintenance and After Care Service

Here, at Ce Solutions we see moveable partitioning walls as an investment and understand how important it is to protect your investments. By routinely servicing and maintaining your moveable partitioning wall, not only will you be ensuring its durability but also keeping its acoustic integrity intact.

With the correct servicing and maintenance, walls can last as long as 25 years. To achieve this, scheduled servicing is by far the best long-term solution. However, damaged walls, or any worn parts, should be repaired quickly by a professional engineer as continued use can cause permanent damage and cause you unnecessary expenses.

Immediate corrective repair is inevitably a better solution than a major overhaul or a replacement wall. Damaged walls can result in health and safety issues, potentially causing problems with insurance - if you are not deemed to have taken reasonable precautions.

Ce Solutions, have locally based engineers dedicated to the servicing and repair of manual, semi-automatic

and fully automatic moveable walls - either through our planned service contracts, or 'call out' repairs. We can support you-whether you have installed a wall originally provided by Ce Solutions, or from any other supplier or manufacturer.

Once all service work is carried out and completed, we will be provided with a full breakdown of repairs and costs. Also, make you aware of any areas of your wall's operation that may need attention in the future. This is combined with notification of any health and safety issues. Leaving you feeling at ease knowing a record of inspection and works has been carried out demonstrating due care.

Small scale replacement of worn and damaged parts can also be carried out during the service (subject to availability of parts). Alternatively, if you are not on a service contract but need your wall repairing, simply call us and we will send an engineer out to carry out an initial inspection and condition report of your installation.



Head Office

01905 422 533

Unit 11C,
Shrub Hill Industrial Estate
Shrub Hill
Worcester
WR4 9EL

t: 01905 422 533 w: cesolutions.co.uk